

CUSTOMER APPROVAL

NAME: _____

DATE: _____

IMPORTANT: BY SIGNING THIS DRAWING YOU ARE APPROVING IT AS IS. IF CHANGES ARE REQUIRED, A NEW DRAWING WILL BE REQUIRED.

NOTES:

1. DAY TANK PACKAGE INCLUDES 12 GAUGE STEEL, RUST PROOFED INTERIOR, PRIMED AND FINISHED PAINTED _____ W/ COVER. TANK PRESSURE TESTED FROM 3.5 TO 5.0 PSI.
2. APPROXIMATE DRY WEIGHT = 399 LB.
3. FOR DETAILS ON THE SYSTEM 2000 PLUS SEE SEPERATE SPECIFICATIONS SHEET.
4. SEE PUMP SPECIFICATION SHEET FOR MORE DEFAULTS. SEE PUMP LIFT WORK SHEETS FOR ADDITIONAL INFORMATION ON PUMP HEAD AND LIFT.
5. OPTIONS (CHECK IF REQ'D)
 - ___ 2" NPT NORMAL VENT (2252)
 - ___ 2" NPT EMERGENCY VENT (2262)
 - ___ OTHER _____
 - ___ OTHER _____

LET	FITTING DESCRIPTION
A	1" NPT FUEL RETURN
B	1" NPT OVERFLOW GRAVITY FEED TO MAIN TANK
C	2" NPT FOR NORMAL VENT
D	1" NPT ENGINE SUPPLY DIP TUBE
E	ELECTRICAL INPUT
F	2" NPT FOR EMERGENCY VENT
H	3/8" NPT FOR DRAIN
J	SYSTEM 2000 PLUS - UL 508 (SEE NOTE #3)
K	MOTOR, 1/3HP, 115VAC, 1PH, 60HZ
L	3/8" NPT FITTING
M	PUMP, 2 GPM HIGH LIFT (SEE NOTE #4)
N	REMOVABLE NON-CONDUCTIVE COVER
P	RUPTURE BASIN ALARM
Q	RUPTURE BASIN - 150%

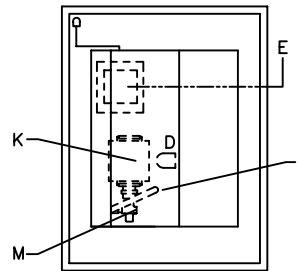

TOP VIEW

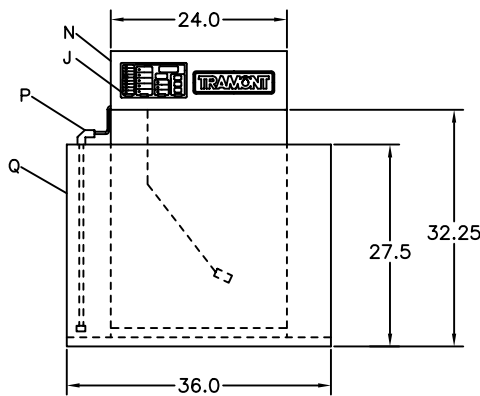

FRONT VIEW

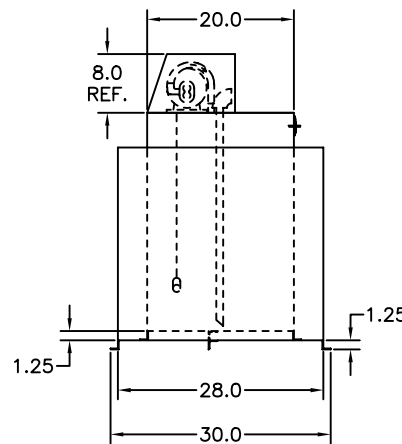

SIDE VIEW

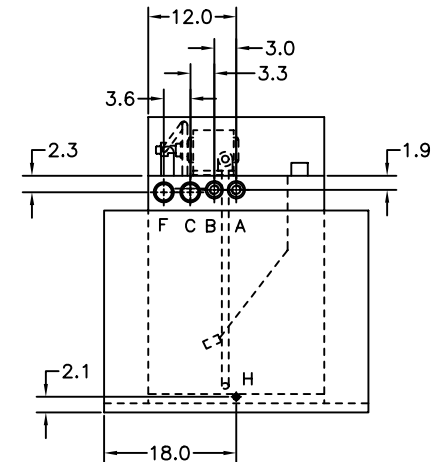

REAR VIEW

LETTER	DATE	DESCRIPTION	NAME
B	05/07/03	WAS 1-1/4" NORMAL VENT CAP (2250)	EAF
A	03/28/02	START	JHP
CHANGE BLOCK (S)			

TRAMONT CORPORATION

SCALE: NTS FRACTIONS = +/- .5 .XX = +/- .125 DRAWN BY: JHP
 DATE: 03/28/02 .X = +/- .250 .XXX = +/- .062 SALES ENG

THIS DESIGN IS THE CONFIDENTIAL PROPERTY OF TRAMONT CORPORATION. FOR USE BY TRAMONT CORPORATION CUSTOMERS FOR SUBMITTAL PURPOSES ONLY. COPYRIGHT TRAMONT CORPORATION, 1998.	
DESCRIPTION:	UTRS-75 DAY TANK WITH RUPTURE BASIN
FOR:	
DRAWING NO.	127-0515