

CUSTOMER APPROVAL

NAME: \_\_\_\_\_

DATE: \_\_\_\_\_

IMPORTANT: BY SIGNING THIS DRAWING YOU ARE APPROVING IT AS IS. IF CHANGES ARE REQUIRED, A NEW DRAWING WILL BE REQUIRED.

NOTES:

1. DAY TANK PACKAGE INCLUDES 10 GAUGE STEEL, RUST PROOFED INTERIOR, PRIMED AND FINISHED PAINTED \_\_\_\_\_ W/ COVER. TANK PRESSURE TESTED FROM 3.5 TO 5.0 PSI.
2. APPROXIMATE DRY WEIGHT = 1,800 LB.
3. FOR DETAILS ON THE SYSTEM 2000 PLUS SEE SEPERATE SPECIFICATIONS SHEET.
4. SEE PUMP SPECIFICATION SHEET FOR MORE DEFAULTS. SEE PUMP LIFT WORK SHEETS FOR ADDITIONAL INFORMATION ON PUMP HEAD AND LIFT.
5. OPTIONS (CHECK IF REQ'D)
  - \_\_\_ 2" NPT NORMAL VENT (2252)
  - \_\_\_ 5" NPT EMERGENCY VENT (2265)
  - \_\_\_ OTHER \_\_\_\_\_
  - \_\_\_ OTHER \_\_\_\_\_

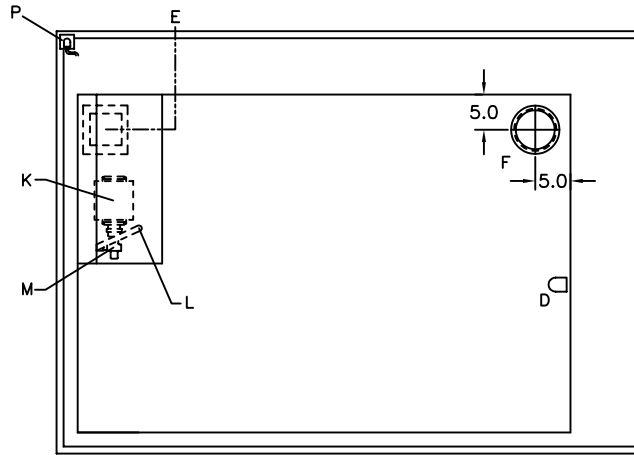

TOP VIEW

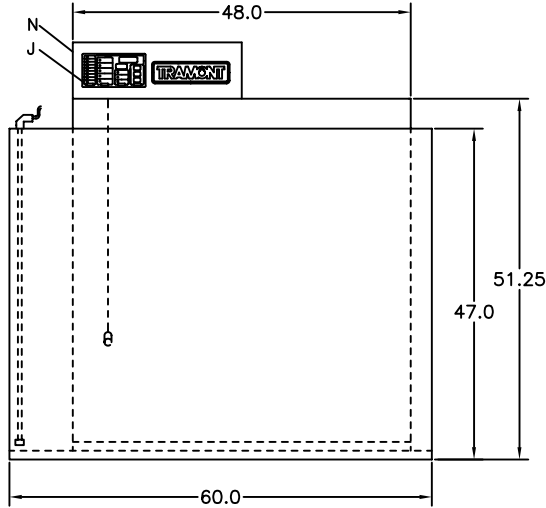

FRONT VIEW

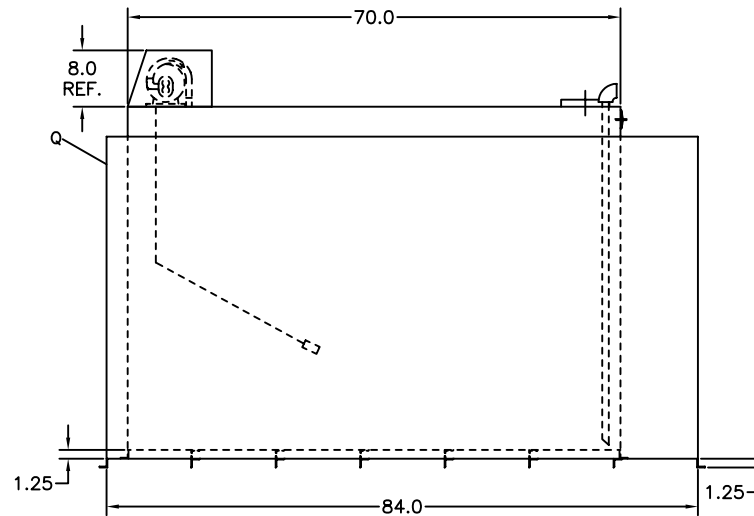

SIDE VIEW

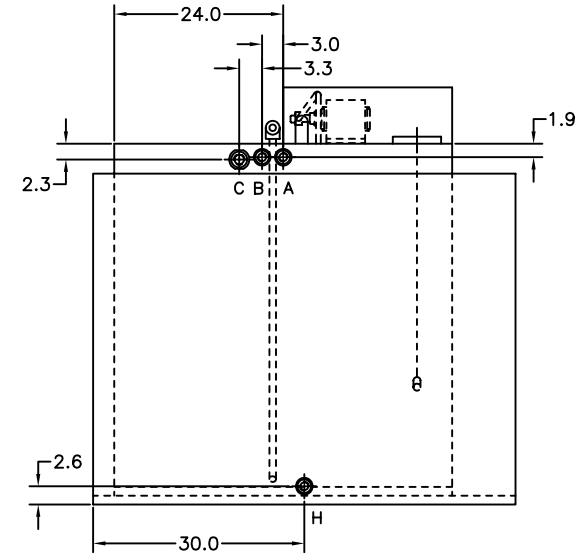

REAR VIEW

| LET | FITTING DESCRIPTION                       |
|-----|---|
| A   | 1" NPT FUEL RETURN                        |
| B   | 1" NPT OVERFLOW GRAVITY FEED TO MAIN TANK |
| C   | 2" NPT FOR NORMAL VENT                    |
| D   | 1" NPT ENGINE SUPPLY DIP TUBE             |
| E   | ELECTRICAL INPUT                          |
| F   | 5" NPT FOR EMERGENCY VENT                 |
| H   | 1" NPT FOR DRAIN                          |
| J   | SYSTEM 2000 PLUS - UL 508 (SEE NOTE #3)   |
| K   | MOTOR, 1/3HP, 115VAC, 1PH, 60HZ           |
| L   | 3/8" NPT FITTING                          |
| M   | PUMP, 2 GPM HIGH LIFT (SEE NOTE #4)       |
| N   | REMOVABLE NON-CONDUCTIVE COVER            |
| P   | RUPTURE BASIN ALARM                       |
| Q   | RUPTURE BASIN - 150%                      |

THIS DESIGN IS THE CONFIDENTIAL PROPERTY OF TRAMONT CORPORATION. FOR USE BY TRAMONT CORPORATION CUSTOMERS FOR SUBMITTAL PURPOSES ONLY. COPYRIGHT TRAMONT CORPORATION, 1998.

TRAMONT CORPORATION

DESCRIPTION: UTRS-700 DAY TANK WITH RUPTURE BASIN

| LETTER | DATE     | DESCRIPTION        | NAME |
|--------|----------|--------------------|------|
| B      | 02/03/04 | CHANGED VENT NOTES | RCS  |
| A      | 03/28/02 | START              | JHP  |

|                |                    |                 |               |
|----------------|--------------------|-----------------|---------------|
| SCALE: NTS     | FRACTIONS = +/- .5 | .XX = +/- .125  | DRAWN BY: JHP |
| DATE: 03/28/02 | .X = +/- .250      | .XXX = +/- .062 | SALES ENG     |

|      |                      |
|------|----------------------|
| FOR: | DRAWING NO. 127-0575 |
|------|----------------------|