

CUSTOMER APPROVAL

NAME: \_\_\_\_\_

DATE: \_\_\_\_\_

IMPORTANT: BY SIGNING THIS DRAWING YOU ARE APPROVING IT AS IS. IF CHANGES ARE REQUIRED, A NEW DRAWING WILL BE REQUIRED.

NOTES:

1. DAY TANK PACKAGE INCLUDES 12 GAUGE STEEL, RUST PROOFED INTERIOR, PRIMED AND FINISHED PAINTED \_\_\_\_\_ W/ COVER. TANK PRESSURE TESTED FROM 3.5 TO 5.0 PSI.
2. APPROXIMATE DRY WEIGHT = 345 LB.
3. FOR DETAILS ON THE SYSTEM 2000 PLUS SEE SEPERATE SPECIFICATIONS SHEET.
4. SEE PUMP SPECIFICATION SHEET FOR MORE DEFAULTS. SEE PUMP LIFT WORK SHEETS FOR ADDITIONAL INFORMATION ON PUMP HEAD AND LIFT.
5. OPTIONS (CHECK IF REQ'D)
  - \_\_\_\_ WEATHERPROOF BASIN
  - \_\_\_\_ 2" NPT NORMAL VENT (2252)
  - \_\_\_\_ 2" NPT EMERGENCY VENT (2262)
  - \_\_\_\_ OTHER \_\_\_\_\_
  - \_\_\_\_ OTHER \_\_\_\_\_

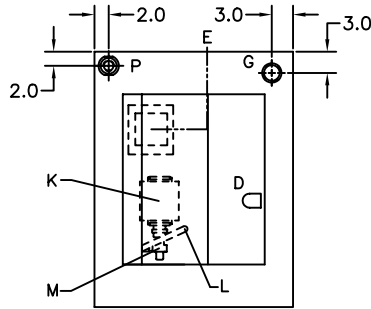

TOP VIEW

LET	FITTING DESCRIPTION
A	1" NPT FUEL RETURN
B	1" NPT OVERFLOW GRAVITY FEED TO MAIN TANK
C	2" NPT FOR OPTIONAL NORMAL VENT
D	1" NPT ENGINE SUPPLY DIP TUBE
E	ELECTRICAL INPUT
F	2" NPT FOR TANK EMERGENCY VENT
G	2" NPT FOR BASIN EMERGENCY VENT
H	3/8" NPT FOR DRAIN
J	SYSTEM 2000 PLUS - UL 508 (SEE NOTE #2)
K	MOTOR, 1/3HP, 115VAC, 1PH, 60HZ
L	3/8" NPT FITTING
M	PUMP, 2 GPM HIGH LIFT (SEE NOTE #3)
N	REMOVABLE NON-CONDUCTIVE COVER
P	1-1/4" NPT BASIN ALARM
Q	WEATHER PROTECTIVE BASIN - 150%

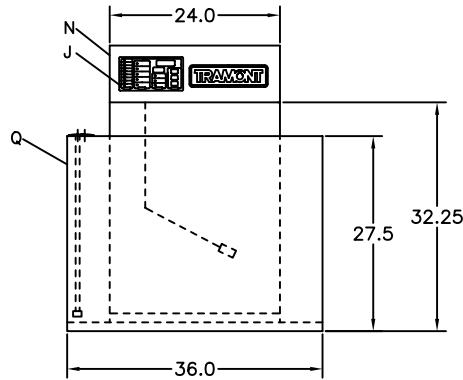

FRONT VIEW

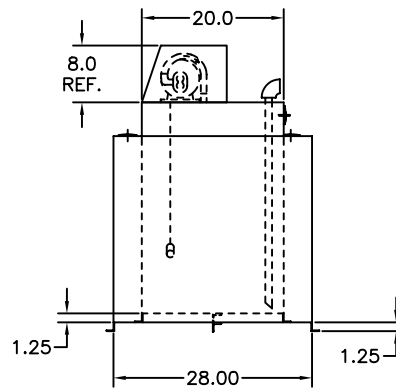

SIDE VIEW

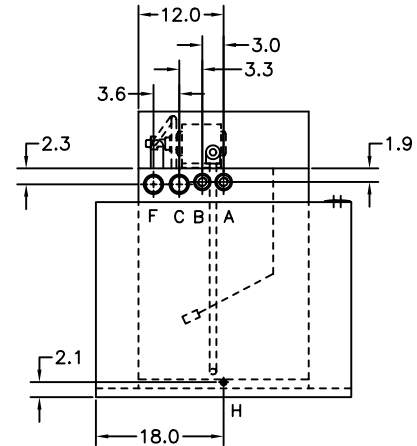

REAR VIEW

THIS DESIGN IS THE CONFIDENTIAL PROPERTY OF TRAMONT CORPORATION. FOR USE BY TRAMONT CORPORATION CUSTOMERS FOR SUBMITTAL PURPOSES ONLY. COPYRIGHT TRAMONT CORPORATION, 1998.

TRAMONT CORPORATION

A	03/11/03	START	JHP
LETTER	DATE	DESCRIPTION	NAME
CHANGE BLOCK (S)			

SCALE: NTS  
 DATE: 03/11/02  
 FRACTIONS = +/- .5 .XX = +/- .125  
 .X = +/- .250 .XXX = +/- .062

DRAWN BY: JHP  
 SALES: \_\_\_\_\_  
 ENG: \_\_\_\_\_

DESCRIPTION: UTRS-60 DAY TANK W/WEATHER P BASIN

FOR: \_\_\_\_\_

DRAWING NO. 127-0720