

CUSTOMER APPROVAL

NAME: _____

DATE: _____

IMPORTANT: BY SIGNING THIS DRAWING YOU ARE APPROVING IT AS IS. IF CHANGES ARE REQUIRED, A NEW DRAWING WILL BE REQUIRED.

NOTES:

- DAY TANK PACKAGE INCLUDES 10 GAUGE STEEL, RUST PROOFED INTERIOR, PRIMED AND FINISHED PAINTED _____ W/ COVER. TANK PRESSURE TESTED FROM 3.5 TO 5.0 PSI.
- APPROXIMATE DRY WEIGHT = 1,662 LB.
- FOR DETAILS ON THE SYSTEM 2000 PLUS SEE SEPERATE SPECIFICATIONS SHEET.
- SEE PUMP SPECIFICATION SHEET FOR MORE DEFAULTS. SEE PUMP LIFT WORK SHEETS FOR ADDITIONAL INFORMATION ON PUMP HEAD AND LIFT.
- OPTIONS (CHECK IF REQ'D)

- ___ WEATHERPROOF BASIN
- ___ 2" NPT NORMAL VENT (2252)
- ___ 5" NPT EMERGENCY VENT (2265)
- ___ OTHER _____
- ___ OTHER _____

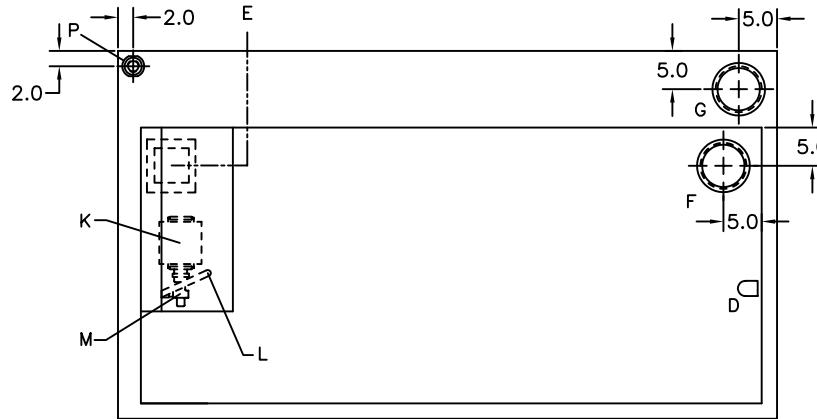

TOP VIEW

LET	FITTING DESCRIPTION
A	1" NPT FUEL RETURN
B	1" NPT OVERFLOW GRAVITY FEED TO MAIN TANK
C	2" NPT FOR OPTIONAL NORMAL VENT
D	1" NPT ENGINE SUPPLY DIP TUBE
E	ELECTRICAL INPUT
F	5" NPT FOR TANK EMERGENCY VENT
G	5" NPT FOR BASIN EMERGENCY VENT
H	1" NPT FOR DRAIN
J	SYSTEM 2000 PLUS - UL 508 (SEE NOTE #3)
K	MOTOR, 1/3HP, 115VAC, 1PH, 60HZ
L	3/8" NPT FITTING
M	PUMP, 2 GPM HIGH LIFT (SEE NOTE #4)
N	REMOVABLE NON-CONDUCTIVE COVER
P	RUPTURE BASIN ALARM
Q	RUPTURE BASIN - 150%

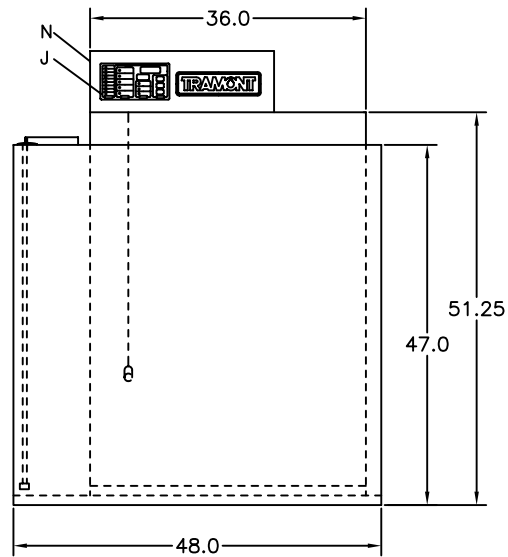

FRONT VIEW

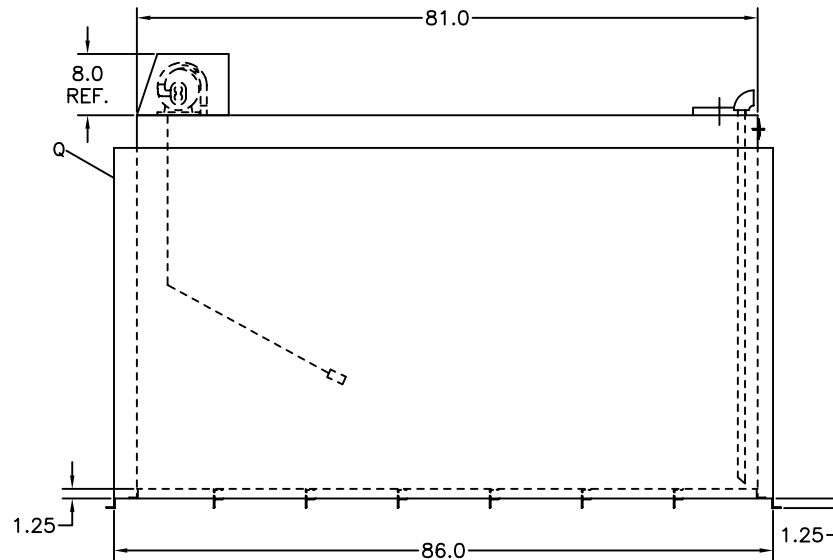

SIDE VIEW

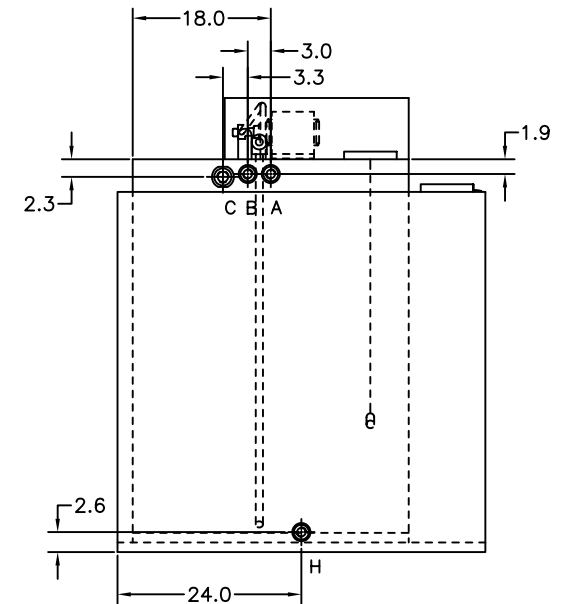

REAR VIEW

THIS DESIGN IS THE CONFIDENTIAL PROPERTY OF TRAMONT CORPORATION. FOR USE BY TRAMONT CORPORATION CUSTOMERS FOR SUBMITTAL PURPOSES ONLY. COPYRIGHT TRAMONT CORPORATION, 1998.

LETTER	DATE	DESCRIPTION	NAME
B	02/03/04	CHANGED NORMAL VENT NOTES	RCS
A	03/28/02	START	JHP
CHANGE BLOCK (S)			

TRAMONT CORPORATION

SCALE: NTS	FRACTIONS = +/- .5	.XX = +/- .125	DRAWN BY: JHP
DATE: 03/28/02	.X = +/- .250	.XXX = +/- .062	SALES ENG

DESCRIPTION: UTRS-600 DAY TANK W/WEATHER P BASIN	DRAWING NO. 127-0780
--	----------------------