

Submittal Manual: Day Tank – TRE Series



Tramont Corporation
3701 N. Humboldt Blvd.
Milwaukee, WI 53212
Ph: 414.967.8800
Fx: 414.967.8811
www.tramont.com

Thank you for choosing Tramont

Included in this manual

- Standard day tank parts
- Installation diagram: Main tank below ground
- Installation diagram: Main tank above ground
- Generic Tramont day tank diagrams
- Tramont day tank specifications
- Standard pump and motor specifications
- Day tank pump capabilities
- Electrical installation guide
- TRE series day tank float switch
- Pump head worksheet: Pump below main tank
- Pump head worksheet: Pump above main tank
- Mechanical and plumbing guide
- Warranty

Warning

This tank has been pressure tested from 3 to 5 psi for weld integrity. However, it has not been designed as a pressure vessel.

This tank was designed, manufactured and intended for diesel fuel only.

This tank is intended for stationary installations only.

The overflow fitting of this atmospheric day tank must be plumbed in a continuous downward path to the main tank without downsizing.

During and overflow condition, any upward plumbing will result in an undesirable fuel pressure situation. This may result in a Diesel Fuel Spill.

If a continuous downward path is impossible, consult installation guide or factory for overflow safety requirements (Installation for main tank above day tank).

NOTE: For convenience the drain can be plumbed (with a valve) into the overflow line.

WARNING: Optional Epoxy Lining
To prevent fuel contamination and deterioration of the epoxy lining, this tank must be allowed to properly cure. The curing time is seven (7) days from the time of application.

This tank lining was applied on _____

Submittal Manual: Day Tank – TRE Series



Tramont Corporation
3701 N. Humboldt Blvd.
Milwaukee, WI 53212
Ph: 414.967.8800
Fx: 414.967.8811
www.tramont.com

Standard Day Tank Parts

Listed below are parts currently standard on Tramont TRE day tanks. The parts on your tank may differ if optional accessories were ordered. For a complete list of parts with descriptions, consult the Tramont Spare Parts List, or contact Tramont.

TRE Series day tank

214080	1/3 HP, 115 VAC, 1 Phase, 60 Hz, Carbonator Mount Motor
214390	2 GPM Pump Carbonator Mount
216150	TRE Top Mounted Pump / Motor Float Switch: Includes bud box, relay, inspection plate & gasket
215890	Fuel Level Gauge, Standard TRE/TRX

Commonly ordered options

While not standardly included on day tanks, these items are commonly requested on day tank orders.

216290	2" NPT Mushroom Cap with screen
216320 – 216360	Appropriately sized Emergency vent
216170	Fuel-in-Basin Switch

Warranty

The Tramont Corporation warrants its products against defects in material or workmanship under normal use and service for a period of 12 months from date of shipment from its plant in Milwaukee, Wisconsin. All obligations and liabilities under this warranty are limited to repairing or replacing at our option F.O.B. Milwaukee, Wisconsin of such allegedly defective units or parts returned, carrier charges prepaid. No liability is accepted for consequential damage or reinstallation labor.

Warranty on accessories furnished by other manufacturers shall be limited by that manufacturer's warranty.

If field service, at the request of the Buyer, is rendered and the fault is found not to be with the Tramont Corporation product, the Buyer shall pay the time and expense of the Tramont Field Representative. Bills for service, labor or other expenses that have been incurred by the Buyer, their customer or agent will not be accepted.

Warranty does not cover failure resulting from improper installation or use.

Changes or repairs made in the field without authorization from Tramont Corporation will void this warranty.

Specification:

Diesel Fuel Day Tank w/ Supply Pump & Motor



Tramont Corporation
3701 N. Humboldt Blvd.
Milwaukee, WI 53212
Ph: 414.967.8800
Fx: 414.967.8811
www.tramont.com

A. Manufacturer Qualifications

Manufacturer shall have a minimum ten years' experience in the design and construction of Underwriters Laboratories (UL) listed day tank systems.

B. Construction

Day tank shall be Tramont Model TRS or approved equivalent, and constructed in accordance with Underwriters Laboratories Standard UL-142. The day tank shall also be constructed in accordance with Flammable and Combustible Liquids Code, NFPA 3-; and The Standard for Installation and use of Stationary Combustible Engine and Gas Turbines, NFPA 37. Day tank shall be made of heavy gauge steel construction. Tank shall include removable, nonconductive top cover for indoor applications, and welded steel, weatherproof cover for outdoor applications. Tank shall be coated with rust inhibitor inside, primed and finish painted outside. The tank shall include the following fittings:

- 1" NPT engine supply
- 1" NPT engine return
- NPT fitting for emergency vent, sized as appropriate.
- 1" NPT overflow.
- 2" NPT normal vent
- 4 ½" square inspection port below electrical controls

The tank shall be provided with atmospheric (normal) vent cap with screen and appropriately sized zinc-plated emergency vent cap. Emergency vent cap shall be spring-pressure operated. Opening

Pressure shall be 0.5 psig; full opening pressure 2.5 psig. Limits shall be marked on top of each vent.

C. Fuel Containment Basin

The day tank shall include a welded steel containment basin to prevent escape of fuel into the environment in the event of a tank rupture. The basin shall be primed and finish painted.

Rupture basin (indoor applications only): The basin shall consist of an open-top, welded heavy gauge steel structure sized at a minimum of 150% of the tank capacity.

Double wall basin (outdoor applications and indoor applications where required by local codes): The basin shall consist of a welded heavy gauge steel structure sized at a minimum of 150% of the tank capacity. The basin will include a welded steel top with an appropriately sized NPT fitting for emergency vent, and appropriately sized zinc-plated emergency vent cap. Emergency vent cap shall be spring-pressure operated. Opening pressure shall be 0.5 psig; full opening pressure shall be 2.5 psig. Limits shall be marked on top of each vent.

D. Leak Detection System

A rupture basin leak detector switch shall be wired into the electronic control module (ECM). This will shut down the supply pump and motor in case of a fuel leak into the containment basin.

Specification:

Diesel Fuel Day Tank w/ Supply Pump & Motor



Tramont Corporation
3701 N. Humboldt Blvd.
Milwaukee, WI 53212
Ph: 414.967.8800
Fx: 414.967.8811
www.tramont.com

E. Electronic Control Module (ECM)

The electronic control module (ECM) shall be Tramont System 2000PLUSTM or approved equivalent. The system shall have a single electrical analog float sensor to provide level signal to the ECM. The following shall be provided as part of the system:

- LED fuel level indicator
- High fuel level warning (activates at 106% of tank capacity)
- Low fuel level warning (activates at 62% of tank capacity)
- Critical low level shut off (activates at 6% of tank capacity)
- Fuel in basin alarm
- Pump control (Pump on at 87% of capacity, off at 100% of capacity)
- ECM functional signal

All warnings shall provide contacts for remote annunciation (3 amps @ 120 VAC). All signals and warnings shall be indicated by LED lights. All warnings shall be provided with normally open and normally closed contacts for remote annunciation. The ECM shall be capable of being manually controlled with "On", "Off", and "Test" buttons. A secure internal test button shall be provided to verify relays' functionality. The system shall be UL-508 listed. Electrical characteristics shall be 120 VAC, 1 phase, 60 Hz.

F. Pumps

The tank shall include a fuel oil pump to draw fuel oil from the main tank to the day tank. Pump capacity shall be sized as

Appropriate, and provide a minimum of 17 feet of vertical lift at sea level. A motor shall be provided of sufficient horsepower to operate the pump; electrical characteristics designated as appropriate.

G. Duplex Pumping System

In applications requiring a duplex pumping system the tank shall include two pump and motor combinations. The pump/motors shall alternate as the lead when the tank is pumping fuel. The lead pump shall activate when the fuel level declines to 87% of tank capacity; the second pump shall activate and operate in tandem with the lead pump if the fuel level declines to 75% of capacity. Appropriately sized solenoid valves with strainers shall be provided on the pump fuel inlets.

H. Reverse Pumping System

A reverse pumping system shall be provided in applications where the main tank's maximum fuel level is at a higher level than the day tank. The reverse pump/motor will return fuel to the main tank in the event the day tank level exceeds 110% of its normal capacity. The reverse pump shall be activated by a separate, critical high level float switch. The reverse pump capacity will be equal to or greater than the capacity of the supply pump. If the tank includes a duplex supply pumping system, the reverse pump shall be equal to or greater than the combined capacity of the two supply pumps.

Submittal Manual: Day Tank – TRE Series



Tramont Corporation
3701 N. Humboldt Blvd.
Milwaukee, WI 53212
Ph: 414.967.8800
Fx: 414.967.8811
www.tramont.com

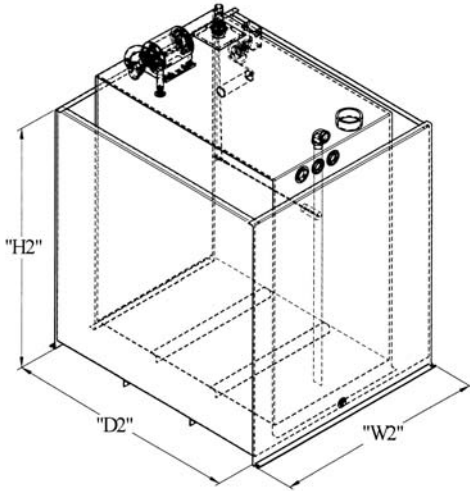

UTRE & BASIN

Dimensions for standard Day Tanks are listed below. Please consult a Tramont service representative if your application requires special dimensions.

Fuel Containment basins for day tanks are optional, most day tank users include them to satisfy local code requirements. Basins are available in standard sizes of 150% and 200% of the tank capacity. A 150% capacity basin is adequate for most applications; however, some jurisdictions require a 200% capacity basin. Check with your local fire marshal or other code enforcement authorities to verify basin requirements. There are two types of containment, open top rupture and closed top double wall basins.

Tank Capacity		Steel Gauge	Emergency Vent NPT	Tank Dimensions Inches			Weight Lbs.		
Gallons	(Liters)			Single Wall			TRS	TRE	TRX
				Length	Width	Height			
10	(38)	12	2	12	24	12	70	63	48
15	(57)	12	2	12	24	16	79	72	57
25	(95)	12	2	12	24	24	98	91	76
50	(189)	12	2	18	24	31	136	129	114
60	(227)	12	2	20	24	31	143	136	121
75	(284)	12	2	24	24	31	158	151	136
100	(378)	12	3	24	24	44	199	192	177
150	(568)	12	3	36	24	44	252	245	230
200	(757)	12	3	46	24	44	297	290	275
275	(1041)	12	4	66	24	44	386	379	364
300	(1136)	12	4	40	36	50	366	359	344
350	(1325)	12	4	46	36	50	400	393	378
400	(1514)	12	4	55	36	50	451	444	429
450	(1703)	12	4	61	36	50	485	478	463
500	(1893)	12	4	68	36	50	524	517	502
550	(2082)	10	4	74	36	50	711	704	689
600	(2271)	10	5	81	36	50	762	755	740
700	(2650)	10	5	70	48	50	804	797	782
800	(3028)	10	5	80	48	50	886	879	864
900	(3407)	10	5	90	48	50	969	962	947
1000	(3785)	10	5	100	48	50	1052	1045	1030

Rupture Basin

A rupture basin is open top. The day tank is placed in the basin. Because water and debris can collect in the containment area, rupture basins are used only for indoor applications.

Double Wall

A double wall basin is closed top. The top is sealed and welded into place. An additional pressure relief vent cap is required to vent the containment area. Double wall tanks typically are used in outdoor applications. Local codes, may require a double wall for indoor applications. Other options may be required to dually weatherproof the tank.

Refer to CHARTS on following page for Basin Sizing

Submittal Manual: Day Tank – TRE Series



Tramont Corporation
3701 N. Humboldt Blvd.
Milwaukee, WI 53212
Ph: 414.967.8800
Fx: 414.967.8811
www.tramont.com

Tank Capacity		150% Containment		Tank Dimensions			Weight		
		Option #		Inches			Lbs.		
Gallons	(Liters)	Open Top	Double	150% Open or Double Wall			150% Open or Double Wall		
		Basin	Wall	Length	Width	Height	TRS	TRE	TRX
10	(38)	2900	7000	16	36	13.5	137	130	115
15	(57)	2905	7005	16	36	17.5	160	153	138
25	(95)	2910	7010	16	36	25.5	206	199	184
50	(189)	2920	7015	22	36	32.5	293	286	271
60	(227)	2940	7020	28	36	32.5	325	318	303
75	(284)	2940	7020	28	36	32.5	340	333	318
100	(378)	2950	7030	28	36	45.5	440	433	418
150	(568)	2960	7035	40	36	45.5	554	547	532
200	(757)	2970	7040	50	36	45.5	650	643	628
275	(1041)	2990	7045	70	36	45.5	840	833	818
300	(1136)	2989	7050	45	48	51.5	795	788	773
350	(1325)	2991	7055	51	48	51.5	999	992	977
400	(1514)	2992	7060	60	48	51.5	1123	1116	1101
450	(1703)	2993	7065	66	48	51.5	1205	1198	1183
500	(1893)	2994	7070	73	48	51.5	1300	1293	1278
550	(2082)	2995	7075	79	48	51.5	1535	1528	1513
600	(2271)	2996	7080	86	48	51.5	1642	1635	1620
700	(2650)	2980	7085	84	60	51.5	1800	1793	1778
800	(3028)	2981	7090	96	60	51.5	1991	1984	1969
900	(3407)	2982	7095	108	60	51.5	2182	2175	2160
1000	(3785)	2983	7100	120	60	51.5	2373	2366	2351

Tank within Containment Only for Overall Height - Add 8" TRS or TRE/X Add 1.25"

Tank Capacity		200% Containment		Tank Dimensions			Weight		
		Option No.		Inches			Lbs.		
Gallons	(Liters)	Open Top	Double	200% Open or Double Wall			200% Open or Double Wall		
		Basin	Wall	Length	Width	Height	TRS	TRE	TRX
10	(38)	2905	7005	16	36	12.5	218	211	196
15	(57)	2910	7010	16	36	20.5	268	261	246
25	(95)	2920	7015	22	36	27.5	363	356	341
50	(189)	2940	7020	28	36	27.5	475	468	453
60	(227)	2940	7020	28	36	27.5	507	500	485
75	(284)	2950	7030	28	36	41.5	581	574	559
100	(378)	2960	7035	40	36	41.5	742	735	720
150	(568)	2970	7040	50	36	41.5	907	900	885
200	(757)	2990	7045	70	36	41.5	1104	1097	1082
275	(1041)	2997	7046	70	48	41.5	1525	1518	1503
300	(1136)	2993	7065	66	48	47	1515	1508	1493
350	(1325)	2994	7070	73	48	47	1775	1768	1753
400	(1514)	2995	7075	79	48	47	1947	1940	1925
450	(1703)	2996	7080	86	48	47	2085	2078	2063
500	(1893)	2980	7085	84	60	47	2296	2289	2274
550	(2082)	2981	7090	96	60	47	2640	2633	2618
600	(2271)	2982	7095	108	60	47	2855	2848	2833
700	(2650)	2983	7100	120	60	47	3121	3114	3099
800	(3028)								
900	(3407)								
1000	(3785)								

Consult Factory for 200% Containment Designs

Tank within Containment Only for Overall Height - Add 8" TRS or TRE/X Add 1.25"

Installation: Electrical Installation Guide: TRE Series Day Tanks



Tramont Corporation
3701 N. Humboldt Blvd.
Milwaukee, WI 53212
Ph: 414.967.8800
Fx: 414.967.8811
www.tramont.com

General

This guide covers the electrical description and installation of the standard Tramont TRE-Series Day Tank. Electrical installation, repair and maintenance should be performed by a qualified electrical service person.

Description

The standard TRE-Series tank pump/motor is controlled by a 1/3 HP rated float switch. The top mounted pump motor control switch is attached into an inspection plate. Includes electrical box, relay & gasket. (Shown below)

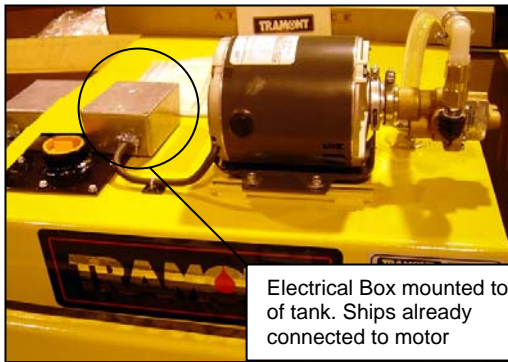

Electrical Box mounted to top of tank. Ships already connected to motor

Electrical box mounted on Day Tank through inspection plate.

To wire the unit, bring hot and neutral leads to float switch electrical box and connect to

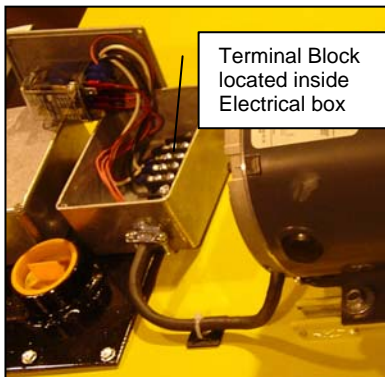

Terminal Block located inside Electrical box

terminal switch. We show line connection through top of electrical box for demonstration purposes. You may send incoming power connection through existing

conduit opening used for motor wires or create another opening where convenient.

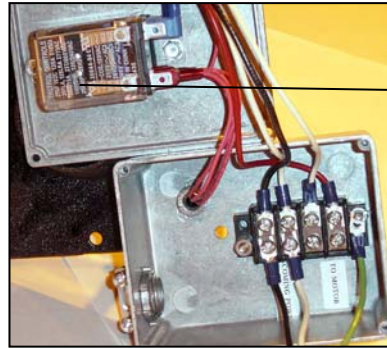

Motor control relay installed on the top of electrical box by Tramont

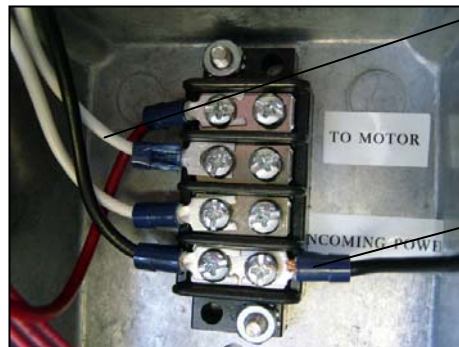

Motor pre-wired by Tramont

Connect Hot lead into corresponding connection



Connect Neutral lead into corresponding connection

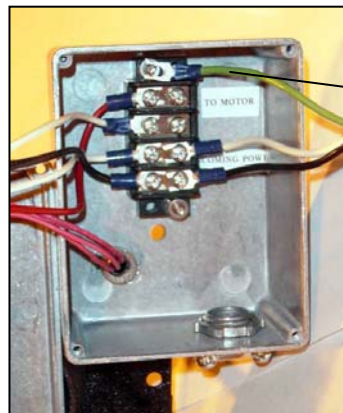

Connect Ground lead to desired area.

Installation: Electrical Installation Guide: TRE Series Day Tanks



Tramont Corporation
3701 N. Humboldt Blvd.
Milwaukee, WI 53212
Ph: 414.967.8800
Fx: 414.967.8811
www.tramont.com



Test

The pump/motor can be tested manually by moving the float switches up and down. This will open and close contacts to operate the motor.

Adjustment

The float switch assembly is adjusted at the factory for your tank capacity.

Electrical options

Following is a list of common electrical options. The number in parentheses is the spare part number should you need to order the item at a future date. Consult the Tramont Spare Parts List for a complete selection of electrical and mechanical options. If additional options are required a Tramont TRS-Series Day Tank may be required.

3430 Heavy Duty TRE Float Switch (216160)

Side mounted. For 3/4 and 1 HP, 120 VAC, 1 phase motors. Fits in 2 1/2" NPT.

3178 Low Fuel Level Switch (216210)

The 50 watt float switch for remote annunciation of low fuel level, installs on inspection plate.

3180 Low Fuel Level Switch with Alarm and Relay (215680)

50 watt float switch and heavy duty 10 amp relay with light for remote and local annunciation.

3181 High Fuel Level Switch with Alarm and Relay (216210)

50 watt float switch and heavy duty 10 amp relay with light for remote and local annunciation.

Specification: Standard Pump and Motor



Tramont Corporation
3701 N. Humboldt Blvd.
Milwaukee, WI 53212
Ph: 414.967.8800
Fx: 414.967.8811
www.tramont.com

Standard Pump and Motor: Specifications

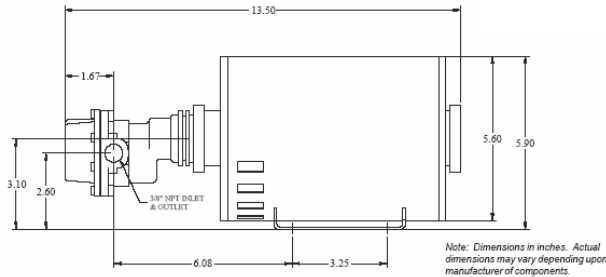

Pump: Heavy duty, 2GPM, self-priming, positive displacement rotary gear pump with corrosion-resistant bronze housing and gears with stainless steel shafts, self lubricating carbon bearings with lip seals. Mounted directed to motor via carbonator style split tang coupling.

Motor: 1/3 HP, open drip-proof (squirrel cage), single phase, auto-thermal protected, bearing supported shaft, Class B insulation for continuous 40 degree C operation, 115 VAC, 60 Hz. Motor rotation may be reversed by reversing wires.

Output: 2GPM at 20 psi (directly into tank) or 1.5GPM at 100 psi. 1 psi = 2.68 feet of head.

Lift: Pump is self-priming and rated at 20 feet of lift (diesel fuel) at sea level. However, pipe diameter, bends, restrictions, hot and cold ambient and other factors may reduce lift. Tramont therefore recommends that the pump/motor be remotely mounted to push fuel in applications requiring more than 17 feet of lift. To ensure continuous self-priming use of appropriately sized foot valve and/or check valve is recommended for all high-lift applications. To avoid damage to motor during start-up, Tramont recommends that the fuel be primed as closely as possible to the pump intake.

Pipe run: If a pipe run of 100 feet or more is required between the main tank and day tank, Tramont recommends the use of a check valve. This ensures that the pump does not have to evacuate a large volume of air during each operation. Even a very small leak in the pipe will prevent self-priming; therefore, Tramont strongly recommends that all pipelines receive a careful pressure check before start-up.

Fuel strainer: The Tramont pump is a high-lift, close tolerance design. Foreign particles in the fuel may prevent proper performance. New installations in particular may have significant quantities of iron scale, rust or other contaminants in the pipeline and main tank. To prevent this matter from clogging and potentially damaging the pump, Tramont recommends the installation of an appropriately designed fuel strainer to the input line.

Please consult the Tramont Day Tank Product Guide or Spare Parts Price List to locate the appropriate accessories for your pump/motor, or contact the factory at the numbers listed above.

Specification: Design Considerations of a Day Tank Pump/Fuel Transfer System



Tramont Corporation
3701 N. Humboldt Blvd.
Milwaukee, WI 53212
Ph: 414.967.8800
Fx: 414.967.8811
www.tramont.com

This general guide is designed to assist the designer in the proper specification of the fuel transfer system. The three main areas to be covered by this paper are pump lift, pump head and pump prime. In critical or borderline applications, an experienced hydraulic engineer should always be consulted.

Pump Lift

A pump will lift fuel by displacing air from suction to discharge line. This creates low pressure in the suction line which allows the higher atmospheric pressure (14.7 psi at sea level) to lift liquid into this vacuum. If a perfect vacuum could be created and maintained fuel could theoretically be lifted to 34 feet. Since a perfect vacuum cannot be created, the lift a pump can actually achieve is approximately 50% of theoretical lift or 17 feet (7.4 psi). To determine the total available lift, the following factors need to be considered:

1. The **vertical distance** the pump needs to lift fuel is the main factor in lifting capabilities. This measurement should be taken from the bottom of the main tank to the pump's inlet port.
2. The **total length of piping and size** is important due to internal friction. This will reduce lift and must be considered. (See table one) All calculations are based on 60°F temperature. Frictional resistance will increase as temperature decreases.
3. **Fitting in the line** will disrupt flow and create friction. These fittings include elbows, tees and unions. (See table two) Valves also need to be checked for possible pressure drops.
4. **Elevation above sea level** is important since the atmospheric pressure acting against the pump's vacuum is reduced, thereby reducing lift. (See table three)

Example One

Given:

Vertical distance	12 feet
Total length of pipe	100 feet
Pipe size	1" in diameter
Pump size	2 GPM
Fitting in line	3 elbows, no valves
Elevation above sea level	3,000 feet

Solution:

Referring to table two, an elbow equals 2.6 feet of pipe. (2.6 x 3 elbows = 7.8 feet) The corrected length of pipe is now 107.8 feet. Referring to table one, the 107.8 feet is divided by 100 and multiplied by the .5 our actual head loss is .54 feet. Therefore, the total lift needed for this system is the vertical distance plus .54 feet or 12.54 feet. Since the pump is safely capable of lifting 15 feet at a 3,000 foot elevation, (see table three), the previous example will perform satisfactorily. However, if a 3/8" diameter pipe would have been used, the head loss would have been 17.63 feet. Adding the vertical distance to this figure equals 29.63 feet. The pump would not be able to lift the fuel. If the plumbing system cannot be built under a 17 foot lift limitation (at sea level), a remote pumping station must then be used. This will be placed between the main tank and the day tank. The proper placement is determined by the pump lift calculation and the following pump head calculations.

Pump Head

the pump's head is the theoretical vertical distance a pump will push fuel. Day tank standard (2 GPM/ 1/3 HP) pumps have 231 feet of head (100 psi). Refer to table four for larger pump and motor discharge rates. Because of electrical convenience the pump is normally located on the day tank, but when pump lift demands are exceeded the remote pumping station is required. This allows us to utilize the head (pushing) capabilities of the pump.

Specification: Design Considerations of a Day Tank Pump/Fuel Transfer System



Tramont Corporation
3701 N. Humboldt Blvd.
Milwaukee, WI 53212
Ph: 414.967.8800
Fx: 414.967.8811
www.tramont.com

To determine the total available head three factors need to be considered:

1. The **vertical distance from the pump to the day tank** needed to push the fuel, is the main factor in head capabilities. This measurement should be taken from the output port on the pump to the day tank's upper most piping connection.
2. The **length and size of pipe** need to be considered in the same manner as the lift calculations.
3. **Fittings** also are calculated in the same manner.

Note: Elevation does not need to be considered in head calculations.

Example Two

Given;

Vertical distance: 150 feet

Total pipe length: 175 feet

Pipe size: 3/4" in diameter

Fittings: 2 elbows, 1 check & 1 solenoid valve

Pump: 7 GPM

Solution:

Referring to table two, a 3/4" elbow equals 2.1 feet of pipe ($2.1 \times 2 = 4.2$). The check valve equals 5.3 feet of pipe. Also, the solenoid valve has a 3 psi drop, (consult manufacturer), or 6.93 feet (3×2.31). The total adjusted length of pipe is: $175 + 4.2 + 5.31 + 6.93 = 191.4$ feet. Referring to table one, 191 feet of 3/4" pipe with a 7 GPM pump interpolates to 29.2 feet of head loss (1.91×15.3). Therefore, total equivalent height is $(150 + 29.2) = 179.2$ feet.

Note: The resulting pressure at day tank is $(231 \text{ feet} - 179.2 \text{ feet})$ divided by $2.31 = 22$ psi. Since the pump will push fuel to a height of 231 feet, this system will work.

Pump Prime

Maintaining the prime on a pump is of critical importance. Fuel must be maintained in the suction side pipe with no air pockets. Foot valves at the main tank or check valves at the day tank can be used to prevent fuel flowing back to the main tank and losing prime.

Pump cavitation is the inability for a pump to discharge fuel properly and can occur for many reasons:

1. Total equivalent lift too high for pump
2. Total equivalent head too high for pump
3. Restrictions in lines
4. Air leaks
5. Improperly plumbed systems

Cavitation can occur gradually and will eventually ruin a pump. Vertical piping loops or "traps" should be avoided when designing a pumping system. Air pockets can become trapped in the high point of the vertical loop, resulting in pump cavitation.

A hand pump is recommended for initial priming to avoid undue wear on the fuel pump. If the fuel pump must be used for initial priming, do not run for more than 60 seconds. Fuel should be flowing within that time.

A fuel strainer is also recommended on the inlet side of the pump. Foreign particles entering the pump chamber will diminish its life expectancy. The strainer should be checked periodically to avoid particle build-up, which would limit pumping capabilities.

Summary

Proper engineering practices should always be used when calculating pump head and especially pump lift. By following these guidelines, costly repair due to improper installations can be avoided.

Specification: Design Considerations of a Day Tank Pump/Fuel Transfer System



Tramont Corporation
3701 N. Humboldt Blvd.
Milwaukee, WI 53212
Ph: 414.967.8800
Fx: 414.967.8811
www.tramont.com

Notes:

1. 1 psi = 2.31 feet of head is the conversion for water. As a general rule, this is a safe conversion for #2 diesel fuel.
2. For more precise calculations refer to the formulas and conversions listed below.
 - A. Head in feet = $\frac{\text{PSI} \times 2.31}{\text{Specific Gravity}}$
 - B. PSI = $\frac{\text{Head} \times \text{Specific Gravity}}{2.31}$
 - C. Specific Gravity of #2 diesel fuel - .88 at 60°F
 - D. Weight of #2 diesel fuel - 7.3 lbs/gallon
3. All calculations are based on a 60°F temperature. Allowances must be made for extreme temperature variances.
 - A. Viscosity of #2 diesel fuel
 - 35 @ 100°F
 - 40 @ 70°F
 - 60 @ 20°F
 - 80 @ 0°F
 - 200 @ -30°F
 - B. An immersion heater is recommended for below 32°F applications.

Table One

Frictional Head Loss (in feet) for 100 feet of standard weight pipe at 60°F at sea level - diesel fuel

GPM	Pipe Size						
	3/8	1/2	3/4	1	1 1/4	1 1/2	2
2	15.2	5.5	1.1	.5	.2		
4	55.5	20.3	5.1	1.4	.5	.2	
7		61.0	15.3	4.6	1.2	.5	
10			26.3	8.5	2.5	.9	2
19				28.5	7.5	3.5	1.2

Table Two

Frictional loss in pipe fittings in terms of equivalent feet of straight pipe

Pipe Size (in.)	Ball Valve	45° Elbow	Std Elbow	Std Tee	Check Valve	Angle Valve	Globe Valve	Diaphragm Valve
3/8	.28	.70	1.4	2.6	3.6	8.6	16.5	
1/2	.35	.78	1.7	3.3	4.3	9.3	18.6	40
3/4	.44	.97	2.1	4.2	5.3	11.5	23.1	
1	.56	1.23	2.6	5.3	6.8	14.7	29.4	
1 1/4	.74	1.6	3.5	7.0	8.9	19.3	38.6	
1 1/2	.86	1.9	4.1	8.1	10.4	22.6	45.2	
2	1.1	2.4	5.2	10.4	13.4	29.0	58.0	

Table Three

Lifting Capacities at various elevations

Elevation	Atmospheric Pressure	Available Lift
Sea level	14.7 psi	17'
1000'	14.2 psi	16'
2000'	13.6 psi	15.5'
3000'	13.1 psi	15'
4000'	12.6 psi	14.5'
5000'	12.1 psi	14'
6000'	11.7 psi	13.5'

Table Four

Pump discharge pressure (psi)

Motor H.P.	Nominal Pump Size (GPM) at 1725 RPM					
	2	4	7	10	19	23
1/3	100	60	2			
1/2		100	20	2		
3/4			40	20		
1			100	40	20	2
1 1/2				80	40	40
2				125	60	60
3				150	100	125

Note: Pump discharge volumes (GPM) can decrease by as much as 25% when higher pressures are required. Please consult factory for borderline consumption rates.

Worksheet: Pump Lift Pump ABOVE Main Tank



Tramont Corporation
3701 N. Humboldt Blvd.
Milwaukee, WI 53212
Ph: 414.967.8800
Fx: 414.967.8811
www.tramont.com

Pump ABOVE Main Tank Total Lift Required for Day Tank Installation

Please complete the following before beginning the worksheet:

Vertical Pipe Length: _____ Pipe Diameter: _____ Elevation Above Sea Level: _____

Horizontal Pipe Length: _____ Pump GPM: _____ In Line Fitting Types: _____

Refer to data tables in Tramont's "Day Tank Pump Capabilities" specification sheet as indicated.

1. Total vertical length of pipe (pump inlet to main tank bottom) _____ ft.
2. Total length of pipe (Vertical & Horizontal) _____ ft.
(Each size pipe in the line must be calculated individually).
3. Additional length as a result of in line fittings (See Table Two) _____ ft.
4. Add results of #2 and #3..... _____ ft.
5. Divide results of #4 by 100 _____ C ft.
6. Pipe size (diameter)..... _____ inch
7. Pump capacity _____ GPM
8. Frictional head loss (See Table One) _____
per 100 ft. (Horizontal)
9. Additional head loss – multiply results of #5 by #8 _____ ft.
10. Repeat steps in items #2 thru #9 for each pipe size used in line..... _____ ft.
11. Total lifting capacity needed (Add results of #1, #9, and #10)..... _____ ft.
12. Elevation above sea level..... _____ psi.
13. Available pump lift..... _____ ft.
14. Subtract results of item #11 from item #13 _____ ft.

- If results of item #14 are positive, the system is properly sized.
- If results of item #14 are negative, the system is beyond a safe lifting capacity.
- If results of item #1 are less than results of #13, **increase pipe size.**
- If results of item #1 are more than results of item #13, **a remote pumping unit is required.**

Worksheet: Pump Head Pump BELOW Main Tank



Tramont Corporation
3701 N. Humboldt Blvd.
Milwaukee, WI 53212
Ph: 414.967.8800
Fx: 414.967.8811
www.tramont.com

Pump BELOW Main Tank Total Head Required for Day Tank Installation

Please complete the following before beginning the worksheet:

Vertical Pipe Length: _____ Pipe Diameter: _____ Elevation Above Sea Level: _____
Horizontal Pipe Length: _____ Pump GPM: _____ Motor HP: _____ In Line Fitting Types: _____

Refer to data tables in Tramont's "Day Tank Pump Capabilities" specification sheet as indicated.

- Total vertical length of pipe (pump inlet to day tank inlet)..... _____ ft.
 - Total length of pipe (Vertical & Horizontal) _____ ft.
(Each size pipe in the line must be calculated individually).
 - Additional length as a result of in line fittings (See Table Two) _____ ft.
 - Add results of #2 and #3..... _____ ft.
 - Divide results of #4 by 100 _____ C ft.
 - Pipe size (diameter) _____ inch
 - Pump capacity _____ GPM
 - Frictional head loss (See Table One) _____
per 100 ft. (Horizontal)
 - Additional head loss – multiply results of #5 by #8 _____ ft.
 - Repeat steps in items #2 thru #9 for each pipe size used in line..... _____ ft.
 - Total head capacity needed (Add results of #1, #9, and #10) _____ ft.
 - Pump discharge pressure (See Table Four)..... _____ psi.
 - Available pump head (Multiply results of #12 by 2.31) _____ ft.
 - Subtract results of item #11 from item #13 _____ ft.
- If results of item #14 are positive, the system is properly sized.
 - If results of item #14 are negative, the system is beyond a safe lifting capacity.

Installation: Mechanical & Plumbing guide: Day Tank Systems



Tramont Corporation
3701 N. Humboldt Blvd.
Milwaukee, WI 53212
Ph: 414.967.8800
Fx: 414.967.8811
www.tramont.com

Mechanical installation

This guide covers the mechanical installation of a standard Tramont day tank system. Installation should be performed by a qualified mechanical installer or plumber experienced in black iron piping, valves and connections. This guide primarily covers "standard" tanks; that is, tanks without optional accessories or equipment. Certain optional devices may require special consideration during installation. For TRE-Series tanks also see "Electrical installation guide: TRE-Series Day Tanks." For TRS-Series tanks also see "System 2000PLUS" specification sheet.

!WARNING!

THIS TANK IS DESIGNED AND CONSTRUCTED TO HOLD DIESEL FUEL ONLY.

Tank placement

Upon receipt of the Tramont day tank, inspect for obvious signs of shipment damage. If damage is visible (dents, water logging, etc.), notify the freight company and file a claim for damages with them. This step must take place on the receiving end of the shipment; Tramont cannot do this for the purchaser or end user. Unpack the unit and inspect closely. The Tramont day tank can withstand normal stresses of shipping. However, rough handling, such as dropping the unit, may result in scratches, dents and damage to tank components and weld seams. Again, if you detect any signs of damage notify the freight company immediately.

Place the tank as close to the gen-set as practical. It should be fully accessible from all sides. The front of the unit must be visible and accessible. Position the tank so that fittings and vents can be easily connected and checked. Make sure that there is room to access the basin/tank drain. Generally a minimum of 6" - 8" from any wall is required for

piping installation. Allowing adequate space for piping will make future repair and maintenance much easier.

Slots are located on the base of the tank if you choose to bolt it to the floor. Complete all piping *before* bolting the tank to any surface. This will make it much easier to correct any misalignment of piping. **The day tank is not designed to absorb the force exerted by improperly aligned pipe. "Forcing" pipes to line up with the fittings may damage the tank.**

Plumbing connections

Day tanks typically are installed with three 90° elbows in the fuel line between the day tank and the point where the line is firmly fixed to a wall or floor. This will facilitate minor adjustments when leading the piping to the tank. Pipe unions should be installed as needed to allow for future breakdown or maintenance of pipes. All threaded connections shall be covered with Teflon™ tape, thread sealant or comparable material. DO NOT use any sealant that is not compatible with #2 diesel oil. All threaded connections must be tightened leak-tight.

IMPORTANT: Gen-set installations generally are not set up so that high pressure can form in piping lines, and **the Tramont day tank is not a pressure vessel.** However, all connections still should be tightened so that the piping can withstand considerable pressure if necessary. Use only clean, new pipe connections. Rust, dirt, tars and other contaminants can prevent proper operation of tank components such as pumps, and may result in damage or destruction of these components.

Installation: Mechanical & Plumbing guide: Day Tank Systems



Tramont Corporation
3701 N. Humboldt Blvd.
Milwaukee, WI 53212
Ph: 414.967.8800
Fx: 414.967.8811
www.tramont.com

Engine supply

The engine supply fitting (1" NPT) is located on the left-hand side at the bottom rear of tanks without a basin.

On tanks with a basin the supply fitting is located on the top rear of the tank, and a dip tube extends to the bottom of the tank. Follow the gen-set supplier's requirements for pipe size; flex hose and connections to the engine.

Fuel return

On tanks without a basin there are two 1" NPT fuel return fittings on the back of the tank. One is located at the lower right-hand side of the tank; the other is located near the top of the tank. On tanks with a basin there is a single fuel return fitting on the back of the tank near the top. The fuel return fittings are for excess hot fuel returned from the engine. If your tank does not include a basin Tramont recommends using the bottom fuel return fitting. Seal the unused fuel return fitting with a 1" NPT black iron pipe plug. Another option is to pipe the fuel return line directly to the main tank, thereby eliminating a possible fuel temperature increase in the day tank.

Overflow

The 1" NPT overflow fitting is located at the upper rear of the tank. It prevents overflowing of the day tank by routing excess fuel directly back to a main tank.

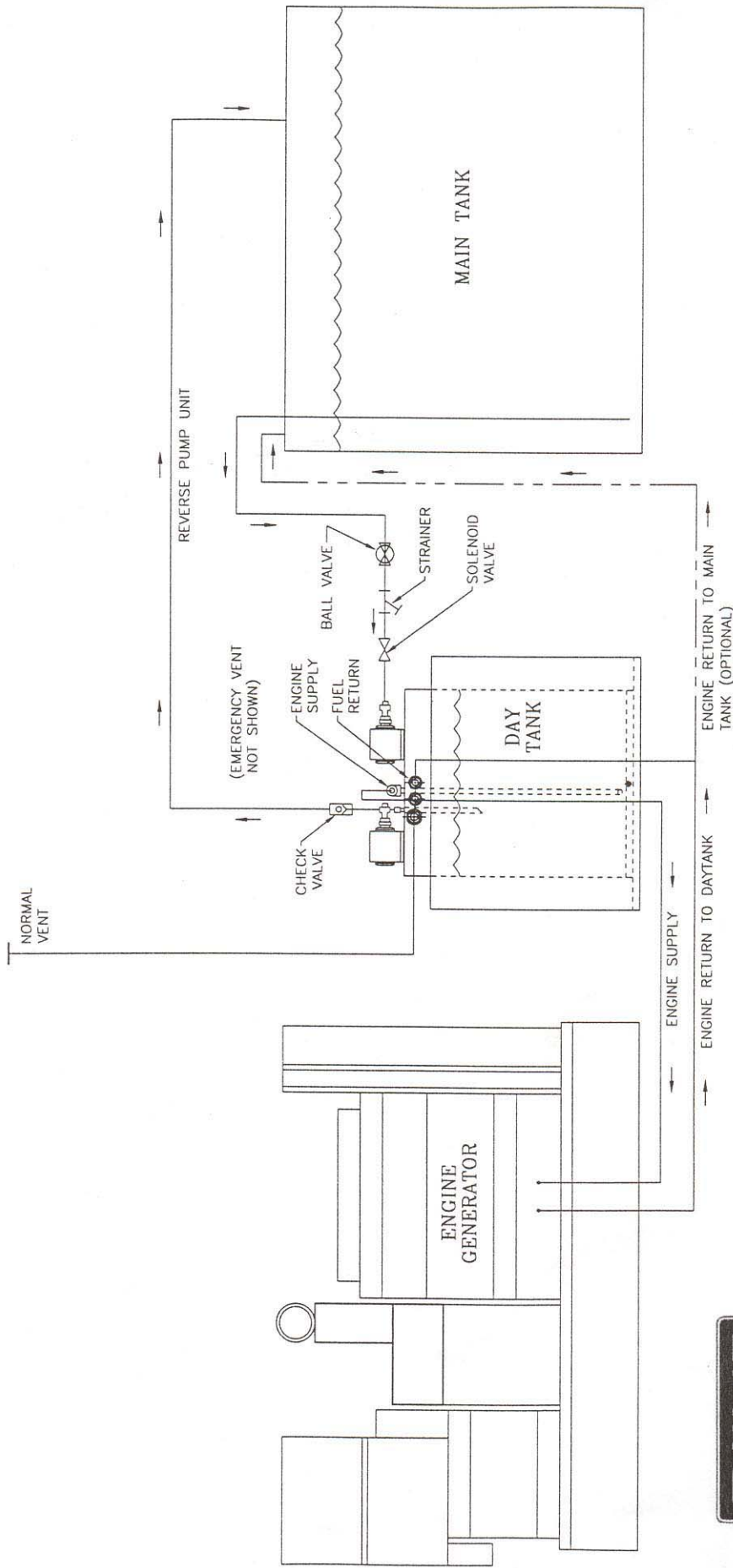

Tramont Corporation

THIS DESIGN IS THE CONFIDENTIAL PROPERTY OF TRAMONT CORPORATION. FOR USE BY TRAMONT CORPORATION CUSTOMERS FOR SUBMITTAL PURPOSES ONLY. COPYRIGHT TRAMONT CORPORATION, 1998.

DESCRIPTION:
DAYTANK INSTALLATION/ MAIN TANK ABOVE GROUND
 DRAWING NO. 119-1199
 PDR:

TRAMONT CORPORATION
 SCALE: NTS
 DATE: 05/29/98
 DRAWN BY: DAK
 CHECKED BY: [Signature]
 FRACTIONS: .XX = +/- .125
 .X = +/- .250
 .XXX = +/- .062

LETTER	DATE	DESCRIPTION	NAME
B	07/02/98	CHANGED THE FUEL RETURN PATH	DAK
A	05/29/98		DAK
CHANGE BLOCK ⑤			

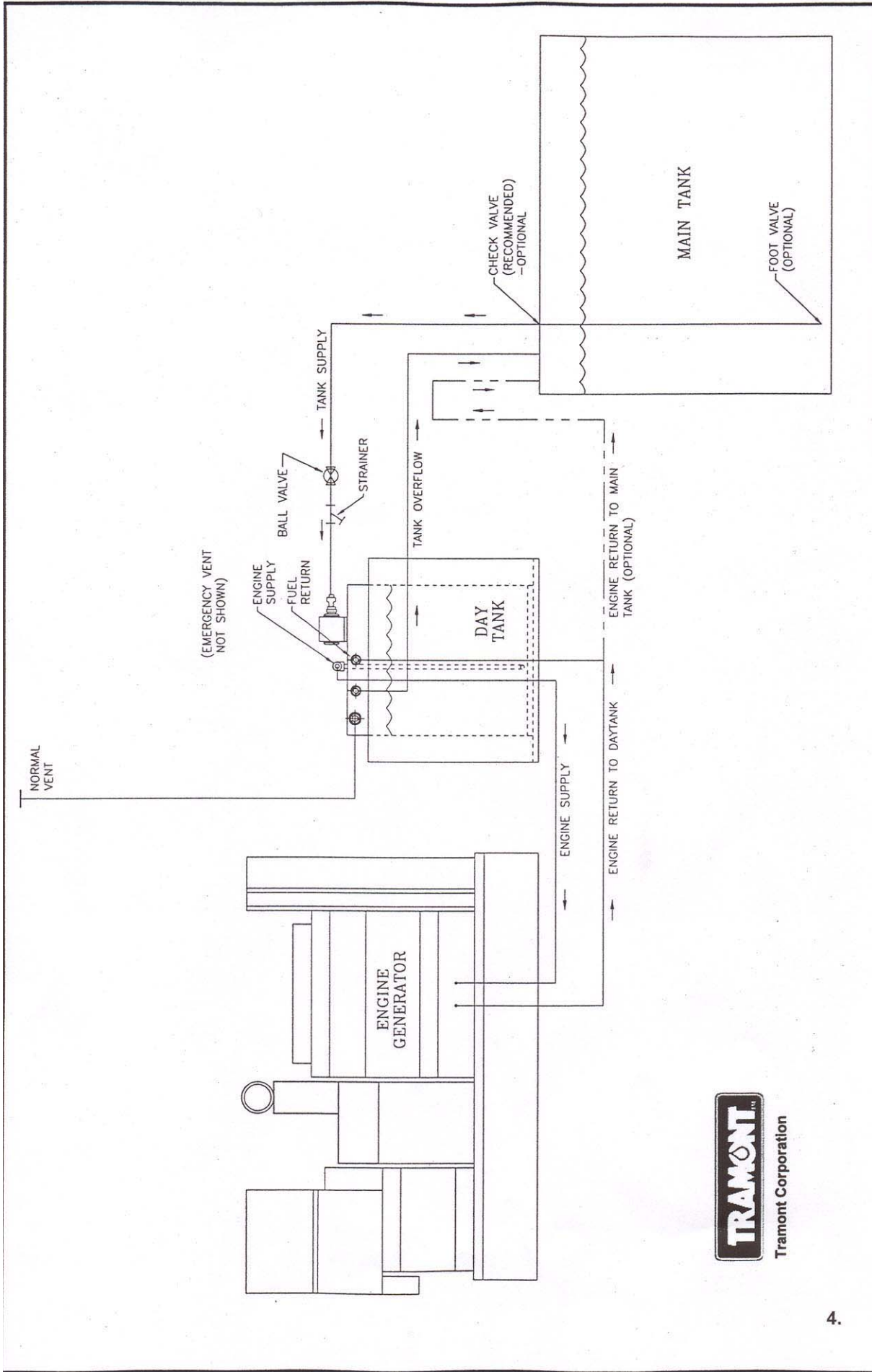

THIS DESIGN IS THE CONFIDENTIAL PROPERTY OF TRAMONT CORPORATION. FOR USE BY TRAMONT CORPORATION CUSTOMERS FOR SUBMITTAL PURPOSES ONLY. COPYRIGHT TRAMONT CORPORATION, 1998.

DESCRIPTION: DAYTANK INSTALLATION/ MAIN TANK BELOW GROUND

FOR: 119-1372

TRAMONT CORPORATION

SCALE: NTS DATE: 07/09/98

SALES: DAK DRAWN BY: DAK

FRACTIONS = +/- .5 .XX = +/- .125 .XXX = +/- .062

X = +/- .250

LETTER	DATE	DESCRIPTION	CHANGE BLOCK
B	08/06/98	ADDED OPTIONS	5
A	07/09/98	START (FROM 119-1199)	

